



Take control with... **ecosmart**
classic



ecosmart Doesn't cost the Earth... **ecosmart** Doesn't cost the Earth



ECOSMART CLASSIC (ES) CONTROL OPTION

“**Ecosmart Classic Control** - UK's leading Energy Efficient 'Plug and Play' solution for over 13 years. Provided with 0-10V BMS interface, trickle and boost as standard”

ecosmart Doesn't cost the Earth... *ecosmart* Doesn't cost the Earth... *ecosmart* Doesn't cost the Earth... *ecosmart*

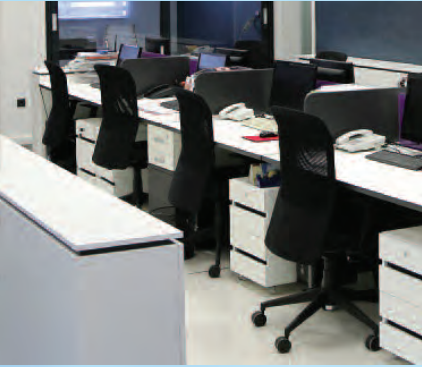

INDEX FOR *ecosmart* CONTROL classic

	PAGE
• ECOSMART CLASSIC - FEATURES AND BENEFITS	4
• ECOSMART CLASSIC - HOW IT WORKS	4
• ECOSMART CLASSIC - SENSORS AND ENABLERS	5 - 8
• ECOSMART CLASSIC - CONSULTANTS SPECIFICATION	9



cosmart Doesn't c



ecosmart ECOSMART CLASSIC CONTROL (ES)

classic FEATURES & BENEFITS

- **QUICK & EASY TO INSTALL** - All controls are pre-assembled, configured and installed directly into the fan or air handling unit, this includes 2, 3 or 4-port motorised valves and actuators, pipework, off coil thermostats and sensors, frost protection, etc. Site time kept to a minimum, quality and efficiency maintained.
- **EASILY ADJUSTABLE** - No need for main VCD, which means no wasted energy or noise generation because the air volume can be precisely set via the integrated speed control, minimum and maximum speeds easily adjusted via Ecosmart commissioning panel.
- **SIMPLE, PRECISE COMMISSIONING** - As recommended in Part L, Ecosmart Classic enables the system to be accurately commissioned via an integrated speed control, minimum and maximum speeds easily adjusted via commissioning panel integral to the control.

	Ventilation mode	Cooling mode*	Heating mode*
Local control	0.00	-	-
OFF / trickle	0.25	-	-
Speed 1	0.50	0.75	1.00
Speed 2	1.50	1.75	2.00
Speed 3	2.50	2.75	3.00
Speed 4	3.50	3.75	4.00
Speed 5	4.50	4.75	5.00
Speed 6	5.50	5.75	6.00
Speed 7	6.50	6.75	7.00
Speed 8	7.50	7.75	8.00
Speed 9	8.50	8.75	9.00
Speed 10	9.50	9.75	10.00

* Only available on relevant unit.

- **QUIETER SYSTEM** - With Ecosmart Classic your system (when combined with sensor) is only at maximum design duty when absolutely necessary. The noise levels within your systems are lower because the fans or air handling units are rarely at full speed.
- **IMPROVED LIFECYCLE** - Ecosmart Classic enables the fan or air handling unit to be run at lower speeds. This reduces the maximum load and wear and therefore increases the overall working life of the units.
- **DEMAND VENTILATION** - To achieve maximum potential savings and the lowest possible energy consumption, combine Ecosmart Classic with sensors to link the fan speed directly to demand. For example by using ES-CO2 or temperature sensors to control fan speed when a room is occupied.
- **HEALTHY ATMOSPHERE** - Ecosmart Classic has a trickle function as standard which when activated, via a simple switch, enables you to set a background ventilation rate, keeping the rooms fresh when unoccupied, whilst still saving energy. System will boost or ramp to maximum design duty when triggered by an Ecosmart or other external device.
- **PLUG IN CONTROLS** - Simple low voltage sensors complete with pre-plugged cable means that any control function is easily achieved. You decide which conditions to monitor and the system will operate at the optimum speed.
- **BASIC BMS INTERFACE** - Integrated BMS features enable any central system to control and monitor the fan or air handling unit via 0-10V signal. This enables full speed control and heating or cooling enable if installed and volt free status indication as standard.
- **PEACE OF MIND** - Warranty is extended to 5 years with Ecosmart Classic. Basic control units only carry a 2 year warranty.

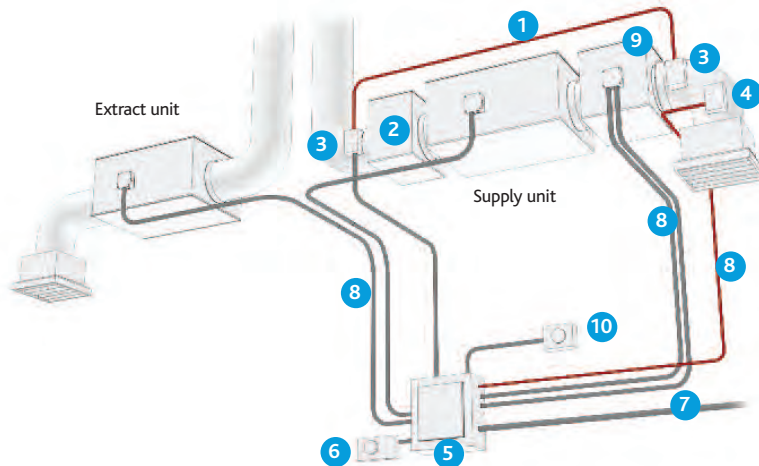

'CONVENTIONAL' SUPPLY & EXTRACT VENTILATION SYSTEM

1. PVC tubing
2. Filter
3. Air pressure switch
4. Temperature switch
5. Control panel
6. User control
7. 230V Electricity supply
8. Electrical cabling 230V
9. Electrical heater
10. Time clock

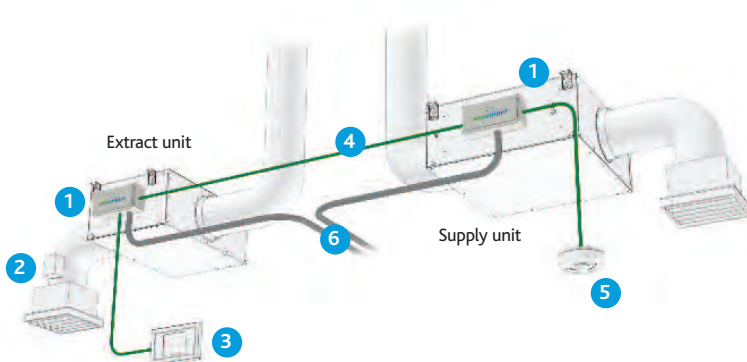

ECOSMART SUPPLY & EXTRACT VENTILATION SYSTEM

1. Integrated control
2. Optional CO₂ sensor
3. User control
4. (SELV) 12V cable
5. Optional PIR sensor
6. 230V Electricity supply

All Ecosmart Classic Systems must include at least one enabler.
(N.B. when used, BMS control and time clocks take over all other enablers).



ES-PIR2 (Enabler)

Detects movement and activates system. Incorporates a system status LED, overrun timer and timer adjustment.



ES-TEMP2 TEMPERATURE (Sensor)

Modulate fan speed based on room temperature. Incorporates two system status LEDs. (Green = OK, Red = Failure) and temperature set point level adjustment.

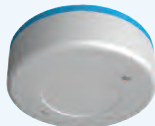

ES-THERMOSTAT2 (Enabler)

Activates the system when the temperature is above set point. Incorporates two system status LEDs. (Green = OK, Red = Failure) and temperature set point level adjustment.

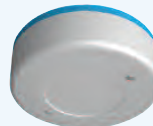

ES-RH2 RELATIVE HUMIDITY (Sensor)

Modulate fan speed based on RH level. Incorporates two system status LEDs. (Green = OK, Red = Failure) and RH set point level adjustment.



ES-AVIZ (Enabler)

When fan failure occurs the AVI will flash a warning. Supplied with pre-plugged 10m length of communication cable.

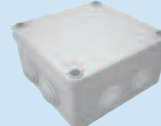

ES-CI SEMI-AUTOMATIC USER CONTROL

Fan, heating & cooling selected by external volt free switch, speed selected by 0-10V signal.

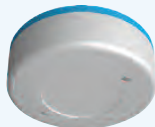

ES-HUMIDISTAT2 (Enabler)

Activates the system when the RH level is above set point. Incorporates two system status LEDs. (Green = OK, Red = Failure) and RH set point level adjustment.

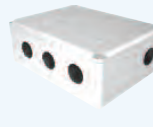

ES-JB JUNCTION BOX

Designed to be compatible with Ecosmart System this unit is supplied with a pre-plugged 10 metre length of communications cable and has 8 further ports.

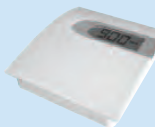

ES-CO2RM (Sensor)

ES-CO2RMPP (Sensor)

Surface mounted room carbon dioxide (CO2) sensors incorporate a temperature sensor. RM = SELV option, RMPP complete with SELV AC powers supply.

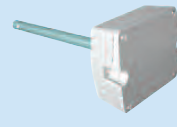

ES-CO2 (Sensor)

Duct mounted sensor to modulate fan speed based on CO2 levels. Connect to fan speed directly. Pre-wired with 2m cable (not adjustable).

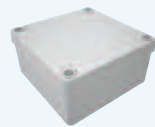

ES-HTCSIG (Enabler)

Signal conditioning circuit for humidity, temperature and CO2 sensors.



SWITCHED LIVE (by others)

Any mains voltage signal connected to the switched live terminal (S/L) in the unit. This affects the connected fan only.

TOUCH SCREENS & MANUAL USER CONTROLS



ES-LCD (Enabler) Touch screen user control in white incorporating time clock facility. This can control the function of the fan by manual setting or using a set of timed programs.



ES-UCF Manual 'on' and 'off' system user/speed control. Incorporates two system status LEDs (Green = OK, Red = Failure).

ECOSMART, BMS AND COMMISSIONING CONTROL OPTIONS

Nuaire fans and Air Handling Units can be provided with the following pre-selected control options, simply and easily by adding letters to the end of the fan code, there is no need to select or specify the controls individually if one of these options are chosen :

ES ECOSMART CONTROLS

The compact Ecosmart control module comes complete with a factory fitted Ecosmart PCB which will control the fan unit within the desired design parameters and provide the interface between all external control devices detailed on these pages.

The Ecosmart control module has the following energy saving components integrally mounted, pre-wired to interface with the purpose made PCB, all components pre-wired, configured and factory fitted by the manufacturer: (Not pre-wired to eg. SQF, Airmover).

- Integral Frequency inverter/speed controller
- Integral maximum and minimum speed adjustment for commissioning.
- Integral adjustable run on timer.
- Integral BMS interfaces - 0- 10V speed adjustment.
- Integral BMS interfaces - Volt free failure and status indication.
- Integral background ventilation switch (trickle switch).
- Multiple IDC sockets for interconnection of sensors or fans using pre-plugged 4-core low voltage cable.
- Pre-programmed with soft start function

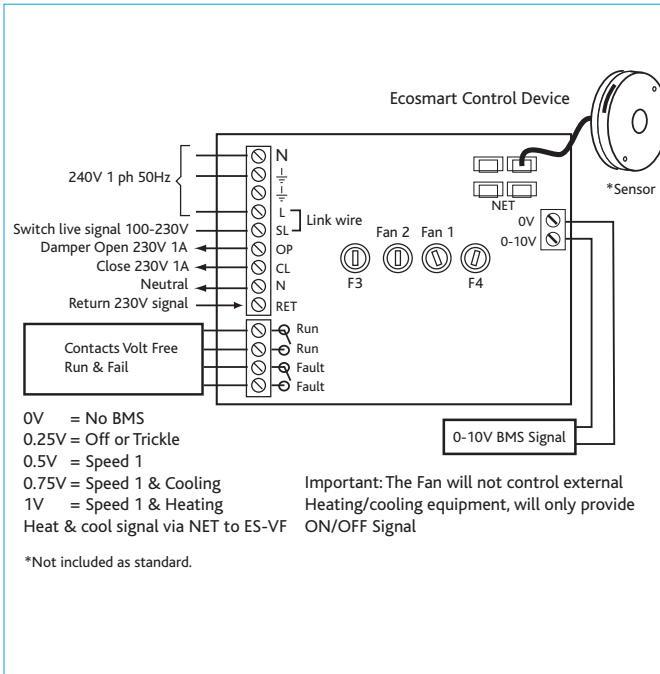

SET UP/COMMISSIONING BOX

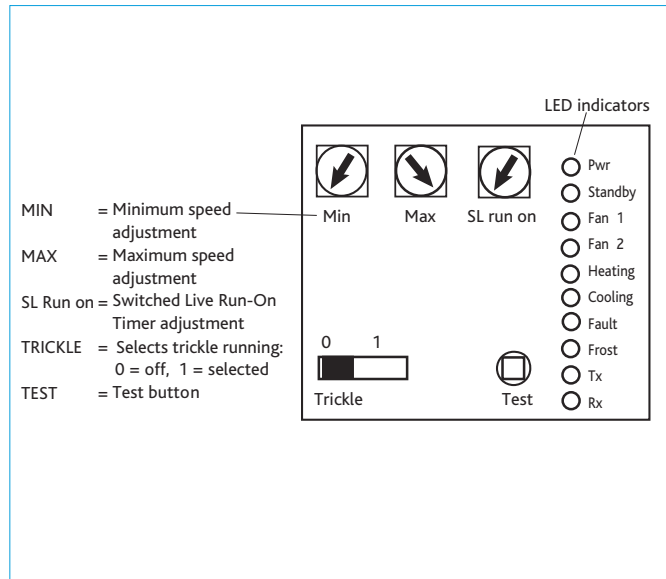

The Ecosmart control module has the following two options fitted as standard.

1) BMS INTERFACES

The Ecosmart control module can be pre-configured to provide the following integrated BMS interfaces.

- 0 - 10 volt input to provide a full BMS interface. This will enable the following functions:-
Switch the unit ON/OFF.
Switch heating or cooling ON/OFF (AHUS with relevant coils).
Switch from low speed to high speed - variable.
Switch from low speed to high speed - trickle and boost principle. Full speed control facility.
- 2 No. Volt free contacts to provide fan run and failure indication to provide system status.
- An integrated commissioning/speed control to accurately commission the system, with minimum and maximum speeds easily adjusted via a miniature dial, as recommended in Part L. This will enable the unit to be configured to run between set parameters thus saving motor power and limiting noise.
- Pre-programmed with soft start function.

2) COMMISSIONING SET UP

The Ecosmart control module can be pre-configured to provide the following integrated commissioning features only.

- An integrated commissioning/speed control to accurately commission the system, with minimum and maximum speeds easily adjusted via a miniature dial, as recommended in Part L. This will enable the unit to be configured to run between set parameters thus saving motor power and limiting noise.
- Minimum and max speeds easily adjusted via miniature dial. The commissioning set up facility directly controls the integrated speed control/frequency inverter.

ENABLING SENSORS

ES-PIR2 SENSOR

The sensor operates with Safe Extra Low Voltage (SELV) with power supplied from the fan unit via the communications cable. The ES-PIR sensor will activate the system when movement is detected. An adjustable 1-60 minute timer is incorporated to provide a run on facility.

When adjustments are made to the sensor, the LED light on the sensor front will flash on and off to show the set point. First, green flashes will indicate the set point in TENS, then red flashes will indicate UNITS.

For example 1 green flash and 5 red flashes show you that the PIR timer is set to fifteen minutes.

ES-THERMOSTAT2

The ES-Thermostat will enable the fan when the ambient temperature is 1°C above the set point and will stop the fan when the temperature is at or below set point. The sensor operates with Safe Extra Low Voltage (SELV) with power supplied from the fan unit via the communications cable. Adjusting the sensor set points. Adjustable temperature setting 10 - 35°C.

After adjustments are made to the sensor, the LED light on the sensor front will flash on and off to show the set point. First, green flashes will indicate the set point in TENS, then red flashes will indicate UNITS.

For example 2 green flashes and 3 red flashes show a temperature set point of 23°C.

ES-HUMIDISTAT2

The ES-Humidistat will enable the Ecosmart fan when the measured humidity level is 2% above the set point and will stop the fan when the humidity is at or below set point. The sensor operates with Safe Extra Low Voltage (SELV) with power supplied from the fan unit via the communications cable. Adjusting the sensor set points - Adjustable RH setting 65 - 85%.

After adjustments are made to the sensor, the LED light on the sensor will flash indicating via a small aperture on the side of the sensor the set point. First, green flashes will indicate the set point in TENS, then red flashes will indicate UNITS. For example 7 green flashes and 3 red flashes show a RH set point of 73%.

SPEED CONTROLLING DEVICES

ES-RH2 HUMIDITY SENSOR

The ES-RH Sensor will vary the ventilation rate automatically according to the measured humidity. The sensor operates with Safe Extra Low Voltage (SELV) with power supplied from the fan unit via the communications cable. The sensor has an adjustable 65-85% RH set point.

After adjustments are made to the sensor, the LED light on the sensor front will flash on and off to show the set point. First, green flashes will indicate the set point in TENS, then red flashes will indicate UNITS.

For example 7 green flashes and 5 red flashes show a set point of 75% RH. Note: fan speed = 0 (i.e. off) at or below the set point

ES-CO2 CARBON DIOXIDE SENSOR - OPERATION

The CO2 Sensor will adjust the fan speed in response to the CO2 concentration in the airflow. The fan speed is divided into 10 steps from minimum (step 1) to maximum (step 10). See table below for response details.

Speed	1	2	3	4	5	6	7	8	9	10
CO2 PPM	502	580	659	737	834	902	980	1059	1137	1215

ES-TEMP2 TEMPERATURE SENSOR

This will modulate fan speed based on room temperature. The sensor operates with Safe Extra Low Voltage (SELV) with power supplied from the fan unit via the communications cable.

After adjustments are made to the sensor, the LED light on the sensor front will flash on and off to show the set point. First, green flashes will indicate the set point in TENS, then red flashes will indicate UNITS.

For example 2 green flashes and 3 red flashes show a temperature set point of 23°C.

Note: fan speed = 0 (i.e. off) at or below the set point.

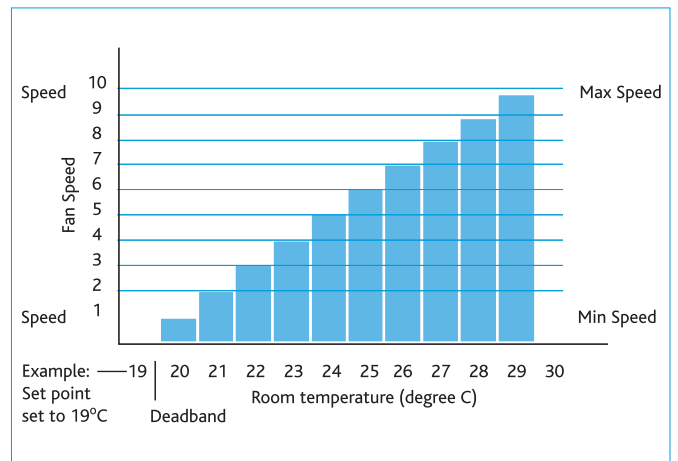

SENSOR RESPONSE - Normal operation (Proportional band over ten 10°C steps)

When temperature rises, the fans will increase speed. (See above) which shows a set point at 19°C. For single phase fans, the speed steps are approximate and actual running speeds will be dictated by the operating pressure of the system and the type of impeller used in the blower. Fan is switched off at set point unless the trickle switch is selected.

ES-LCD (TIME CLOCK INCLUDED)

The ES-LCD Time clock will switch the system on and off at pre-determined times set by the user. This digital time clock will override the user control for effective on/off operation or any other enabling device eg. PIR. The time clock operates on Safe Extra Low Voltage and is powered from the fan control module. The connection is made into any 'NET' socket on the fans integral control module. See I&M for further details.

ES-LCD INCLUDES:

Ventilation, Automatic Heating & Cooling Enable/Disable.

Air off temperature in devices with coils is pre-set within the commissioning tools and cannot be controlled remotely.

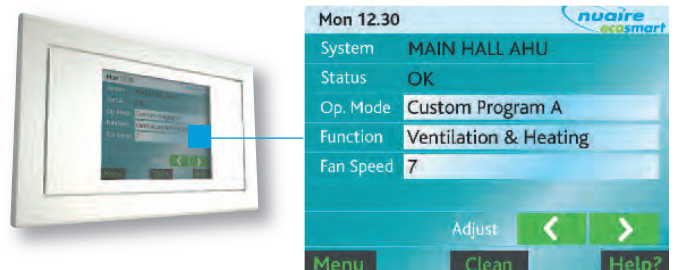

ES-CI (ECOSMART CONTROL INTERFACE)

Enables any Ecosmart unit to be controlled via any remote non Ecosmart switching device or item of plant.

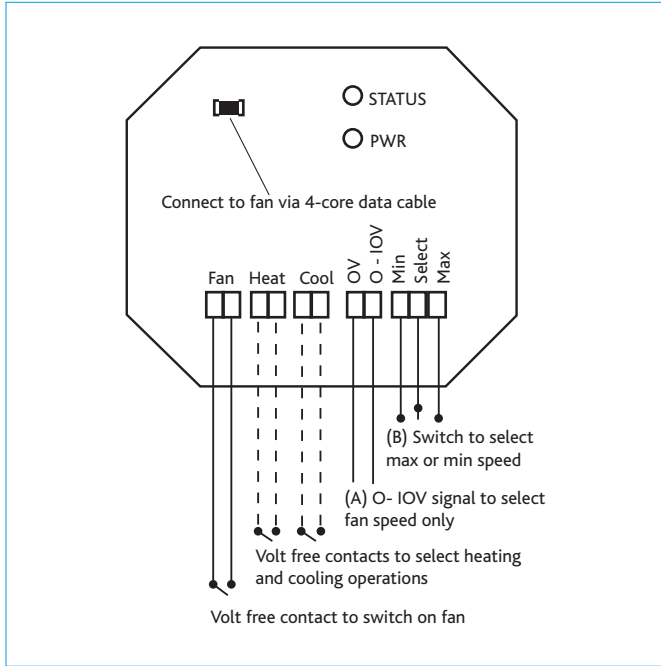

As the room CO₂ and temperature rises, the fan speed will progressively increase in steps until the upper threshold values are reached. When both CO₂ and temperature readings are in operation, whichever reading that results in higher fan speed will be used by the fan unit.

The threshold values and other operations can be adjusted by setting DIL switches on the PCB to different positions.

Note 1: As supplied; the default operation of the sensor will be based on carbon dioxide reading. If operation with both carbon dioxide and temperature is desirable then change position of switch 7 to 'ON'.

Note 2: use switch 8 to change the off state (see table below).

TEMPERATURE THRESHOLD SWITCHES 1-9

Switch settings	3	2	1	Threshold temperatures	
				T1 (°C)	T2 (°C)
	Off	Off	Off	25	28
	Off	Off	On	24	28
	Off	On	Off	23	28
	Off	On	On	22	28
	On	Off	Off	25	30
	On	Off	On	24	30
	On	On	Off	23	30
	On	On	On	22	30

ES-CO2RMPP TEMPERATURE SENSOR

CO₂ and temperature sensor supplied with (SELV) AC power supply. The sensor will monitor the carbon dioxide (CO₂) and temperature (see note 1) is designed to be wall mounted within the room. If either reading reaches the low threshold values (i.e. C1 & T1) see opposite, then a signal will be sent to start running the fan at minimum speed. The ES-CO2RMPP is supplied with (SELV) AC power supply.



The lower and upper threshold values can be adjusted as shown in the following table.

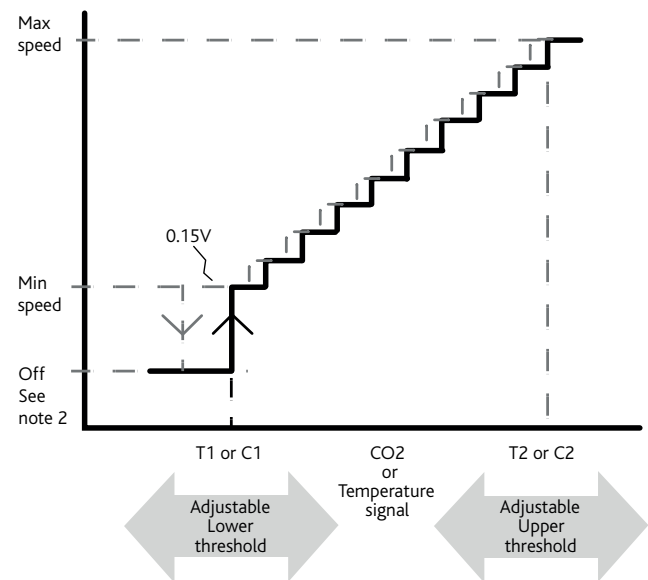

Note: Default operation is CO₂ only. To select temperature option as well please refer to I&M.

ES-CO2RM TEMPERATURE SENSORS

CO₂ and temperature sensor requires SELV power supply by others.

The logo for Ecosmart Classic, featuring the word "ecosmart" in a green sans-serif font with a blue swoosh above it, and the word "classic" in white inside a green rounded rectangle below it.

CONSULTANTS SPECIFICATION

ECOSMART CLASSIC - DEMAND CONTROLLED VENTILATION

Provides the facility for energy saving via an intelligent stand-alone AHU function with local diagnostic status indication, or allows convenient integration with the client BMS with a minimal co-ordination requirement.

The factory fitted Ecosmart Classic control includes:-

Integral infinitely variable speed /duty control for the supply and extract fans, with independent minimum, maximum and offset adjustment (up to 40%) for accurate commissioning.

- The control assembly is side mounted with a 90° rotation facility (XBC Range only) for wiring and commissioning adjustments in restricted access conditions. (260mm access allowance is required).
- The control features a run on timer and "background" ventilation function, and is provided with unit status indication, run and fail relays and interface connections for Ecosmart Classic sensors/enablers and system dampers.
- The heat exchanger bypass is automatically operated according to temperature and a pre-defined strategy. ***The heating output (LPHW or electric) is automatically regulated to control the Air - Off condition.
- The Ecosmart control module can additionally be connected to provide the following integrated BMS interfaces.
- 0 - 10 volt inputs will enable the following functions:- Switch the unit on/off, variable speed / duty control, switch from low speed to high speed, enable heating / cooling.
- 2 No. Volt free contacts give fan run and failure unit status indication.

Units fitted with Ecosmart Classic control have a 5 year warranty.

FOR MORE INFORMATION

www.nuaire.co.uk

COMMERCIAL

www.nuaire.co.uk/commercial

AIR HANDLING UNITS

www.nuaire.co.uk/boxerahu



NUAIRE LIMITED

Western Industrial Estate | Caerphilly | CF83 1NA

t +44 (0)29 2085 8200 | f +44 (0)29 2085 8222 | e info@nuaire.co.uk

www.nuaire.co.uk

As part of our policy of continuous product development Nuaire reserves the right to alter specifications without prior notice. Telephone calls may be recorded for quality and training purposes.

