

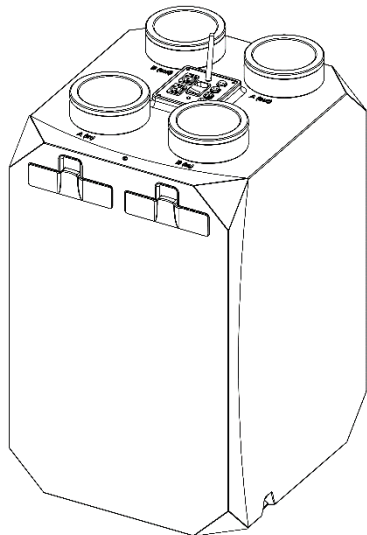

## **BSK NOTUS HV HEAT RECOVERY UNIT**

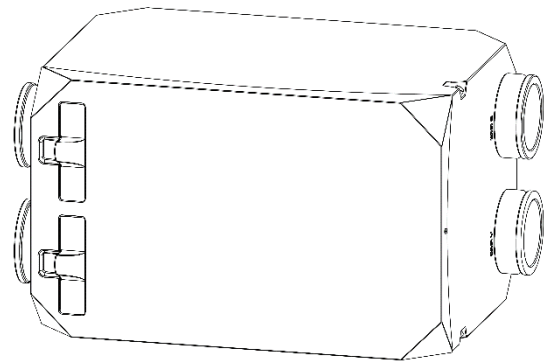

**Vertical Orientation**



**Horizontal Orientation**

## **MONTAGE AND SERVICE MANUAL**



## **PREFACE**

Thank you for selecting the BSK NOTUS HV heat recovery device. This manual is designed to provide comprehensive information to users regarding the components, functionalities, and maintenance of the BSK NOTUS HV.

The BSK NOTUS HV heat recovery unit excels in delivering superior indoor air quality while optimizing energy consumption. This is achieved through a state-of-the-art plastic plate, counter-flow heat exchanger, facilitating efficient heat transfer between fresh and exhaust air. The innovative design ensures not only high performance but also exceptional thermal conductivity.

Our commitment to user-friendly experiences is reflected in the straightforward assembly, operation, and maintenance of these devices. The incorporation of advanced controls and a range of accessory options empowers users to tailor the system to their specific requirements.

By choosing BSK NOTUS HV, you are investing in a solution that seamlessly combines efficiency and ease of use, offering you unparalleled control over your indoor environment.

## **WARRANTY DETAILS**

BSK stands behind the quality of its heat recovery units, guaranteeing them free from structural weld flaws, material defects, or manufacturing problems, including faults in fans, damper systems, or electronics. However, BSK does not assume responsibility for damages resulting from improper or irresponsible use conditions.

### **Coverage:**

- The warranty covers all mechanical and electrical components, including fans, motors, and circuitry, for a period of 2 years from the date of the customer's invoice.

### **Exclusions:**

- Damage resulting from unauthorized repairs, modifications, or replacement of parts without written permission from BSK or an authorized service is not covered by the warranty.
- Replacement of G4/F7 cassette filters, not performed by BSK, falls outside the warranty scope.

### **Repair and Exchange:**

- Failures related to structural weld flaws, material defects, or manufacturing problems, as well as faults in fans, damper systems, or electronics, are eligible for repair or exchange during the warranty period.

### **Service Personnel and Costs:**

- BSK's warranty covers the replacement of spare parts for fans, damper motors, and electronic components. However, it does not include service personnel wages or operation/maintenance costs.

### **Transportation and Exchange Costs:**

- If the defect is within the warranty coverage, all transportation and exchange costs, along with technical staff appointments, will be covered by the authorized service. Otherwise, these costs must be borne by the customer.

## HEAT RECOVERY UNIT'S PARTS

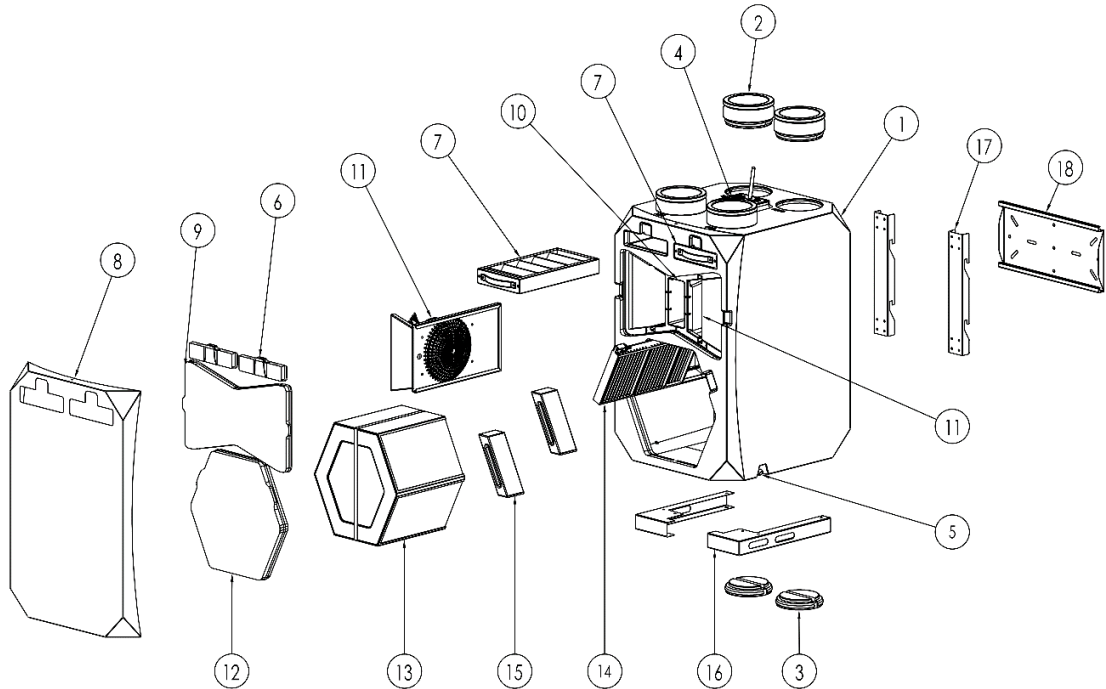

- |                                  |                               |
|----------------------------------|-------------------------------|
| <b>1.</b> Body                   | <b>10.</b> Control board      |
| <b>2.</b> Air duct connections   | <b>11.</b> Fan cage           |
| <b>3.</b> Air duct stoppers      | <b>12.</b> Heat exchanger lid |
| <b>4.</b> Electrical connections | <b>13.</b> Heat exchanger     |
| <b>5.</b> Drainage connections   | <b>14.</b> Bypass damper      |
| <b>6.</b> Filter doors           | <b>15.</b> Bypass blocks      |
| <b>7.</b> Cassette filters       | <b>16.</b> Foot parts         |
| <b>8.</b> Front panel            | <b>17.</b> Wall hanging parts |
| <b>9.</b> Fan lid                | <b>18.</b> Wall fixture part  |

## 1. Body

The body of the NOTUS series heat recovery units is made of Expanded Polypropylene (EPP) material. EPP is a highly versatile closed-cell bead foam that provides a unique range of properties, including outstanding shock absorption, thermal insulation, water and chemical resistance, exceptionally high strength to weight ratio and 100% recyclability.

The device body is designed to minimize pressure losses. The inner surfaces of the device are smooth and have no sharp edges.

The lightweight nature of the EPP material significantly reduces the overall weight of the unit compared to metal units, thus bringing the weight down under 20kg so that 1 person can easily lift it up.

## 2. Air Duct Connections

All air connections should be made with a duct connection with the according diameter of either  $\varnothing 125$  or  $\varnothing 160$  mm.  $\varnothing 125$ mm is the inside diameter and  $\varnothing 160$  mm is the outer diameter of the connection part.

The device needs 4 air connections;

### **Fresh air in:**

Gets the fresh air from outside into the device.

Fresh air in should be connected to either A(in) or B(in) depending on the installation site.

### **Fresh air out:**

Gives the heated fresh air to the inside. Also called "supply air"

Fresh air out should be connected to A(out) if A(in) is Fresh air in, or B(out) if B(in) is Fresh air in.

### **Exhaust air in:**

Gets warm inside air into the device. Also called "extract air"

Exhaust air in should be connected to B(in) if A is Fresh air, or A(in) if B is Fresh air.

### **Exhaust air out:**

Deposits the used, cooled air to the outside

Exhaust air out should be connected to B(out) if A is Fresh air, or A(out) if B is Fresh air.

The device orientation and user preference of these connection may vary. The unit can be oriented in 8 different ways. To change the device orientation, you need to put the air duct connection parts and the air duct stopping parts into their respective holes.

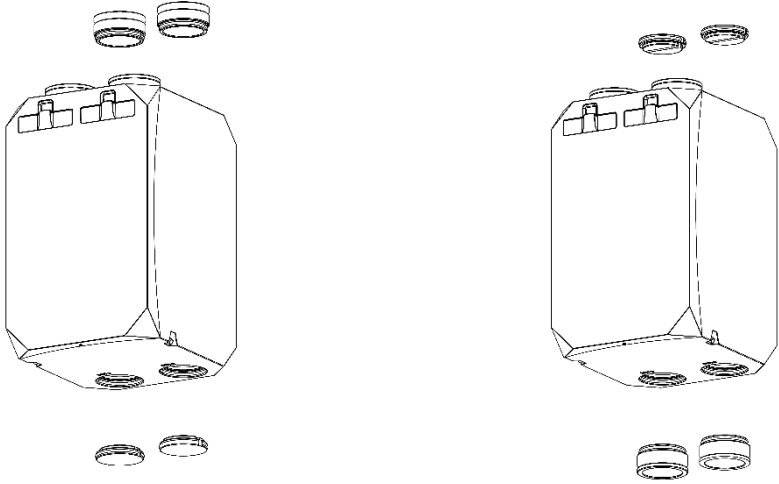

To change the device orientation from its standard configuration, remove the 2 air connection pieces from the back and the 2 air stopper pieces from the bottom and replace them with each other.

**3. Air Duct Stoppers**

Use the air duct stopper pieces to change the orientation of the device, plugging the unused air exits.

## Vertical Device Orientation Options

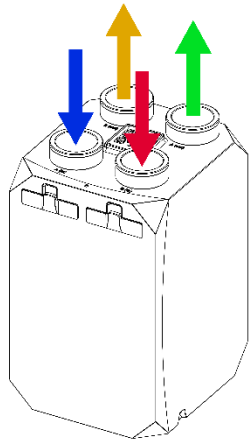

**Vertical Top In / Top Out Left**  
V-TITO-L

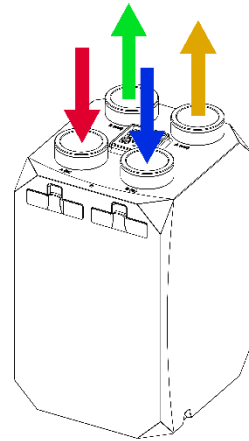



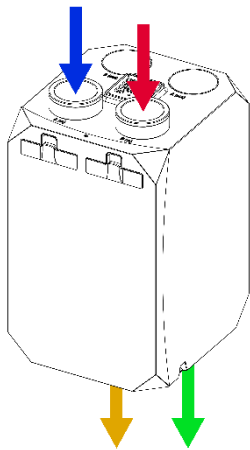

**Vertical Top In / Top Out Right**  
V-TITO-R

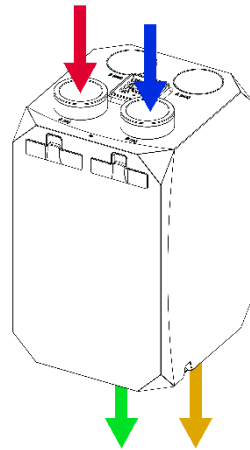

**Vertical Top In / Bottom Out Left**  
V-TIBO-L



**Vertical Top In / Bottom Out Right**  
V-TIBO-R

	Fresh air in
	Exhaust air in
	Fresh air out
	Exhaust air out



## Horizontal Device Orientation Options

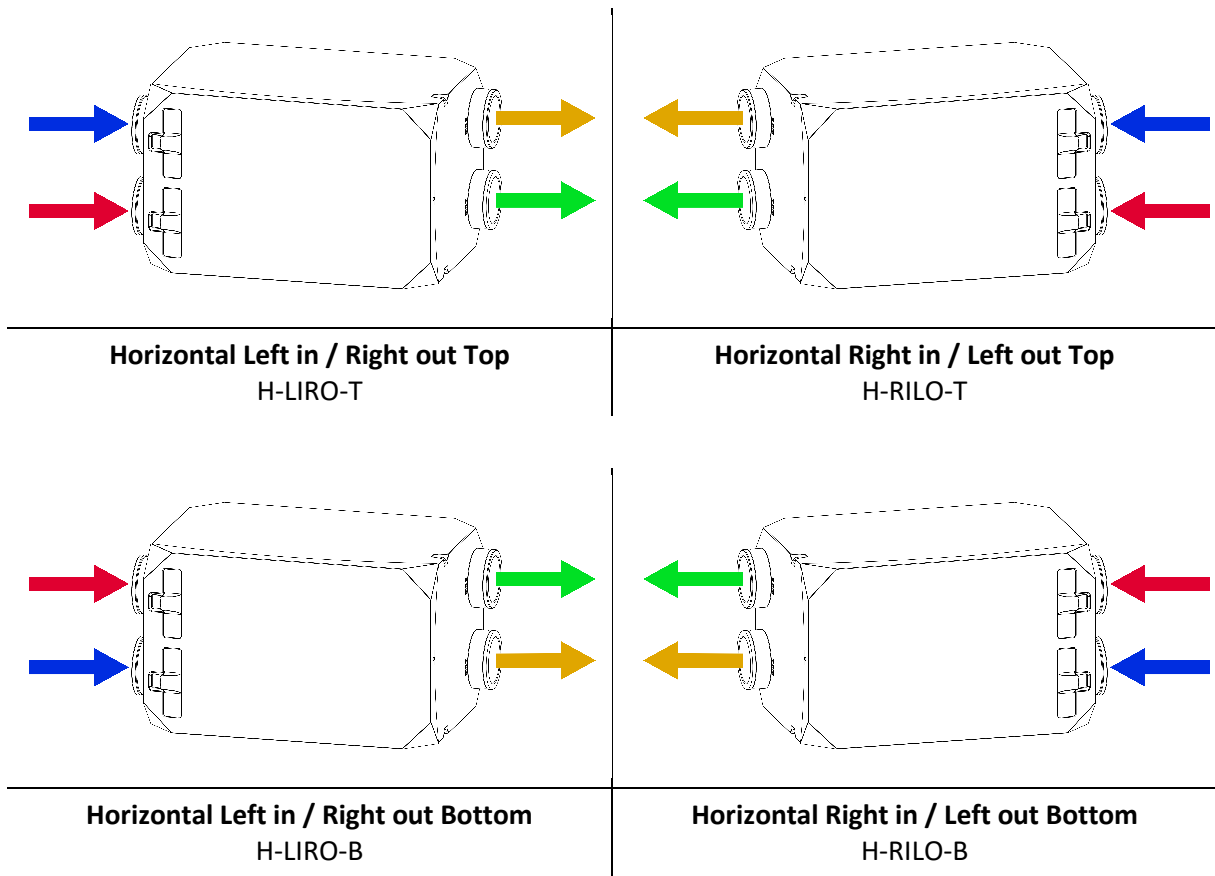

	Fresh air in
	Exhaust air in
	Fresh air out
	Exhaust air out

## 4. Electrical Connections

BRHR units are designed to be plug and play, and all the electrical connections come with pre-connected sockets for this purpose. You do not need to wire connections to the control board, just plug the correct sockets to their respective areas on the device to use accessories.

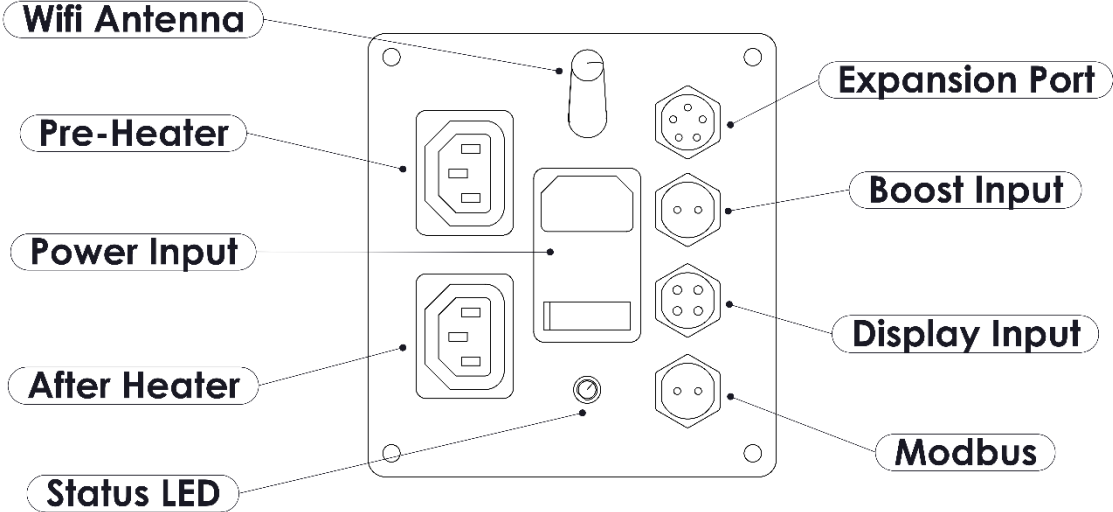

### A. Power Input

This is the main power source of the device. The socket is equipped with an on/off switch. "I" is the **ON** and "O" is the **OFF** position.

The switch must be on **OFF** position before all the connections to the device are made.

The socket has a 250V 10A glass fuse.

### B. Status LED

Status LED will turn on to indicate when the filters are full. The differential pressure sensor inside the device will monitor filter pressure and it will warn user when the filter needs a change.

The LED will turn off automatically when the sensor detects clean filters.

### C. WiFi Antenna

A 15cm 2.4Ghz antenna is used to increase the range of the WiFi.

### D. Display Input

Display connection is used to connect the BSK Touch Display control panel to the device. To learn how to use the

### E. Modbus Port

The device can be connected to a building management system (BMS) via the ModBus protocol. The A and B pins of the ModBus port is shown below.

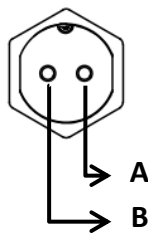

### F. Boost Input

The device can be connected to a kitchen aspirator or another basic switch via the boost port. This dry-contact connection signals the device when the external switch is turned on and it enters External Boost Mode.

To connect, wire the 2 inner cables of the connector cable (sold separately) to the on-off switch. DO NOT connect the cable to the power directly, the input is Dry Contact and should only be connected to a switch.

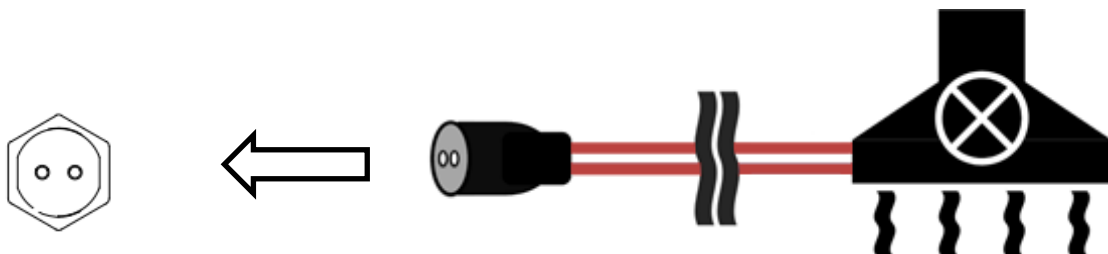

## **G. Expansion Port**

Expansion port on the device is used to connect various extension boards to make your device even more capable. If you need to add new features to your ventilation device in the future, you can do it so with the expansion port.

## **H. Electric Pre-heater**

In cold climates, where weather conditions are often drop below 0 °C, it is recommended to use an electrical pre-heater before the fresh air intake to heat up the air, in order to protect the device's insides from frost formation.

Pre-heater will activate if the fresh air intake temperature drops below defrost temperature. This set temperature can be adjusted between -10 and 0 °C.

The heater must be installed at least two diameter distances away from the duct connection of the heat recovery unit.

To connect the pre-heater, plug the pre-heater's power cord to the corresponding socket on the device.

## **I. Electric/Water After-heater**

An electric or water heater can be added to the device, after the supply air duct, to further heat the air going inside of the house.

The heater must be installed at least two diameter distances away from the duct connection of the heat recovery unit.

There is an electrical valve on the hot water inlet of the water heater which is used to control the hot water flow into the coil. The cable from this valve should be connected to the "water/electrical heater port" of the device.

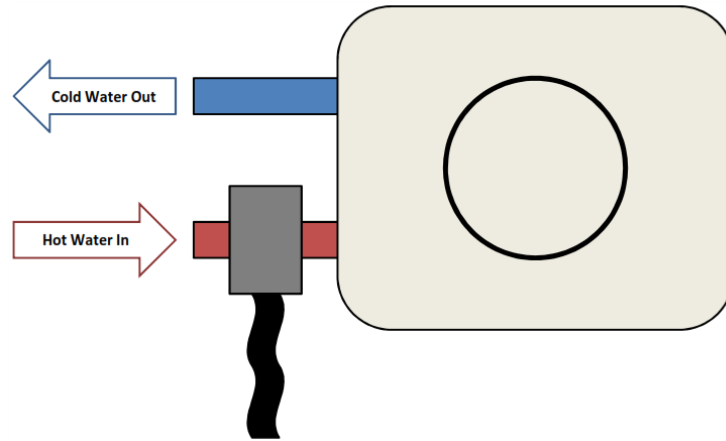

To connect the electric / water heater, plug the heater's power cord (if electric heater) or the power cord of the valve (if it is water heater) to the socket on the device.

## 5. Drainage Connections

To collect the condensing water droplets which can be formed inside the device. The drainage pipe has been taken out to be able to connect to the waste water system.

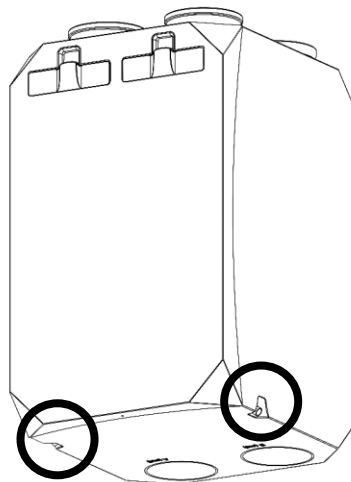

The drainage pipes must be connected to the waste water line before the device is started. The connection is made with a  $\varnothing 19$  mm pipe.

The drain must never be led directly to the gutter, this can cause water damage when it freezes outside

The connection of the drain must always have a water lock to prevent smells from the waste water line.



## 6. Filter Doors

There are detachable filter doors over the service door which can be easily removed to access the filters without completely removing the front panel first.

## 7. Cassette filters

There are 2 cassette filters after both the fresh air inlet and the extract air intake ports which clean the air going into the device to protect the heat exchanger and other commodities from dust and abrasive particles.

There is a red LED indicator on the device which lights up when the filter is full. There will also be warnings on the touch display if it is connected.

Device uses a differential pressure sensor to sense the filter dirty status. When new filters are inserted, the warnings will turn-off automatically.

1. To change the filters, open the filter cover by pulling it from its handle.
2. Pull the filter from its slot.

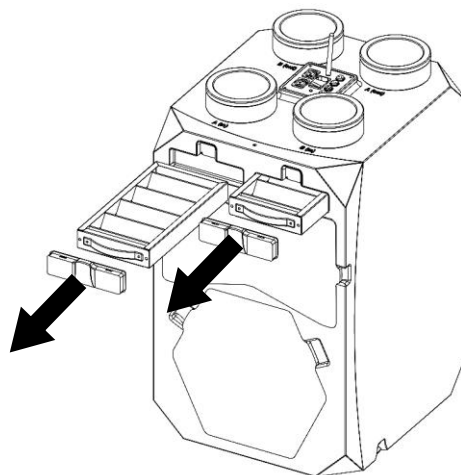

3. After removing the dirty filter, put the new filter back in the slot.
4. Put the filter doors back.

## 8. Front panel

The units have a sheet metal front panel which can be removed easily.

To open the device, first remove the 2 screws on the top and bottom of the front panel like shown below, and take off the cover.

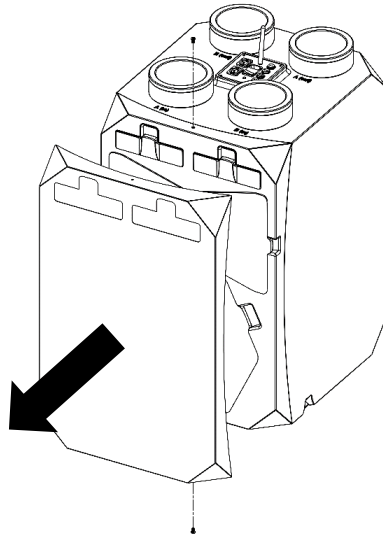

## 9. Fan lid

Fan lid is the butterfly shaped under the front cover which protects the fan cages and control boards.

To remove the fan lid, pull from the ears on either side of the lid.

## 10. Control board

Control board is in the middle of the unit, under the fan lid. It is where the electrical connections terminate inside the device.

1. To remove the control board, first turn off the device and then unplug it from the main power plug.
2. After that, disconnect the wires from their sockets one by one,
3. Remove the 2 silicone tubes colored red or blue which are connected to the differential pressure sensor on the control board.
4. Remove the Wi-Fi antenna cable which is connected to the Wi-Fi module on the back side of the control board.
5. To install a new control board, put the cables and tubes back into their respective sockets.

### Control Board Socket Layout

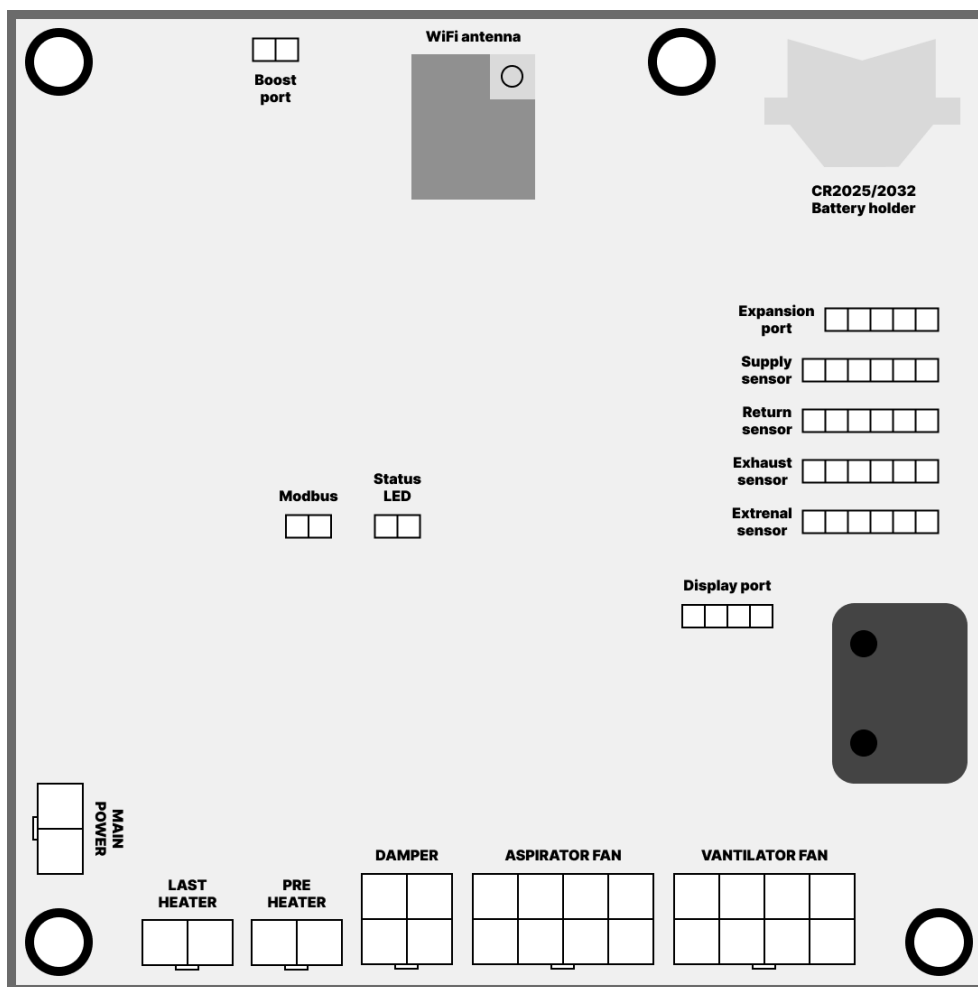



## 11.Fan cage

All devices utilize modern EC motors with backward curved fan blades for maximum efficiency.

1. To change the fans, open the front panel first.
2. Then remove the fan cover door shaped like a butterfly,
3. Unplug the fan cables from the control board in the middle of the device,
4. Then simply pull the fan cage out of its slot.

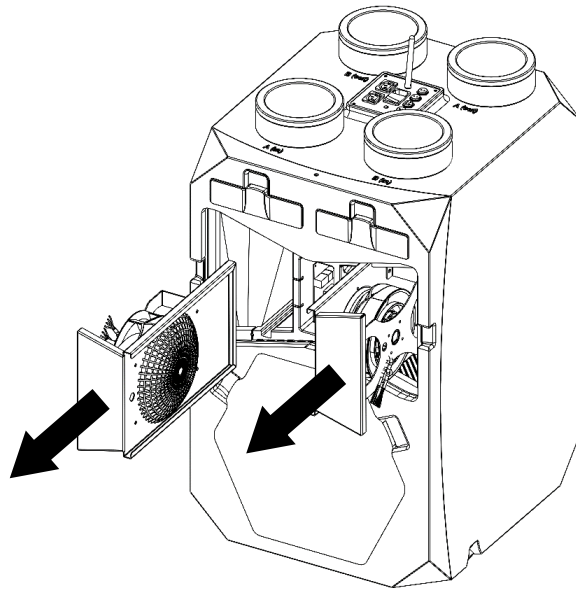

5. After removing the fan, put the new fan back into its slot.
6. Reconnect the fan cables to the control board.
7. Push the fan cover door back to its place,
8. Put the front panel back on the device and secure it with its 2 screws.

## 12.Heat exchanger lid

Heat exchanger lid is the hexagonal shaped under the front cover which protects the fan cages and control boards.

To remove the fan lid, pull from the ears on either side of the lid.

## 13.Heat exchanger

Plastic plated, high efficiency, hexagonal counter flow heat exchangers are used in all of the units.

1. To change the heat exchanger, open the front cover first,
2. Then pull the hexagonal heat exchanger lid from its place,
3. Last, pull the heat exchanger from its seat.

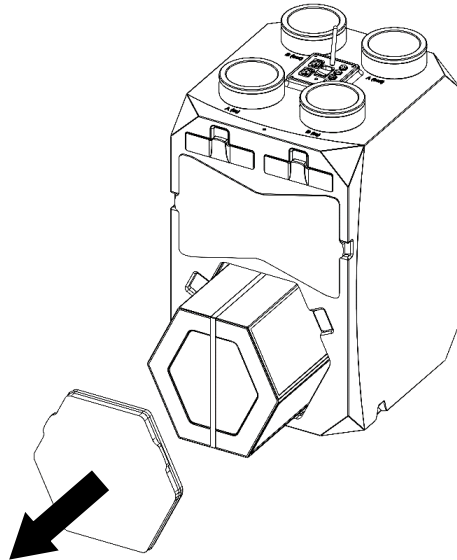

4. After removing the heat exchanger, put the new heat exchanger back in the slot.
5. Push the hexagonal heat exchanger cover door to its place,
6. Put the front panel back on the device and secure it with its 2 screws.

## **14. Bypass damper**

Automatic bypass damper allows the bypass canal to be opened and closed, enabling the free-cooling mode where the outside air bypasses the heat exchanger and routed directly into the house.

## **15. Bypass blocks**

Bypass block parts are used to create the bypass channel on the back of the heat exchanger. Using these parts, the side of the bypass damper could be changed to match the airway connection setups.

1. To change the side of the bypass damper, open the front cover first,
2. Then pull the hexagonal heat exchanger cover door from its place,
3. Pull the heat exchanger from its seat.
4. After removing the heat exchanger, unplug the bypass damper cables.
5. Then slightly angle the bypass damper so that it can be removed and pull it from its slot.

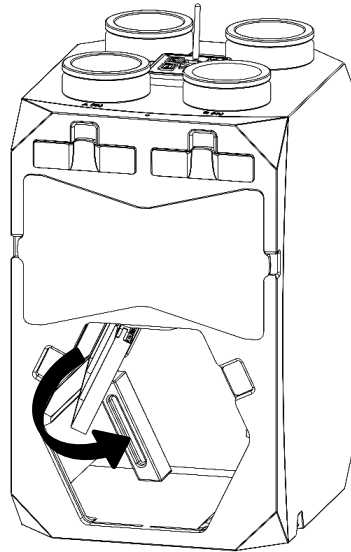

6. If you want to change the side of the bypass damper, also remove the 2 bypass back pieces from their slots.

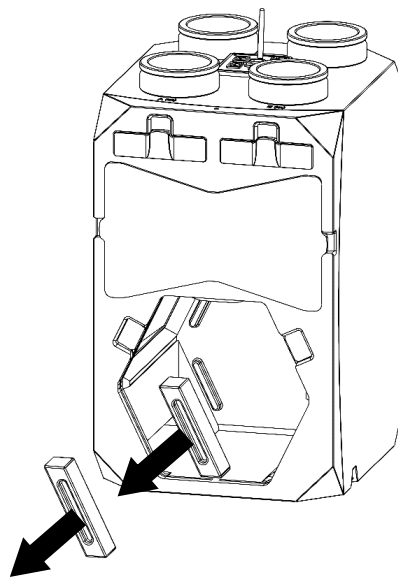

7. Reverse their direction and then put them back on the opposite corners.
8. Put the bypass damper with a slight angle to its new slot, and then push it in.
9. Reconnect the bypass damper cables.
10. Push the heat exchanger back into its slot.
11. Push the hexagonal heat exchanger cover door back to its place,
12. Put the front panel back on the device and secure it with its 2 screws.

## Free-cooling mode

When the outside temperature is warm enough, heat recovery from the inside air is not always necessary. For these situations, usually on seasonal changes, free cooling mode is activated and the air flow is directed from the heat exchanger to the by-pass canal. This will decrease the pressure drop and the load on the fans can work with less energy, improving the power consumption of the device.

In automatic free-cooling mode the bypass damper will open if the set temperature is within  $\pm 2^{\circ}\text{C}$  of the external temperature. Or if set to ON or OFF mode it will permanently stay opened or closed depending on the selection.

To learn how to set free-cooling modes, please check the touch display user guide.

## 16. Foot parts

If the device is going to be hang on a wall, then there is no need to use these parts.

To install the foot parts, use 4 of the included M5 screws to secure both parts to the threaded plastic inserts under the device.

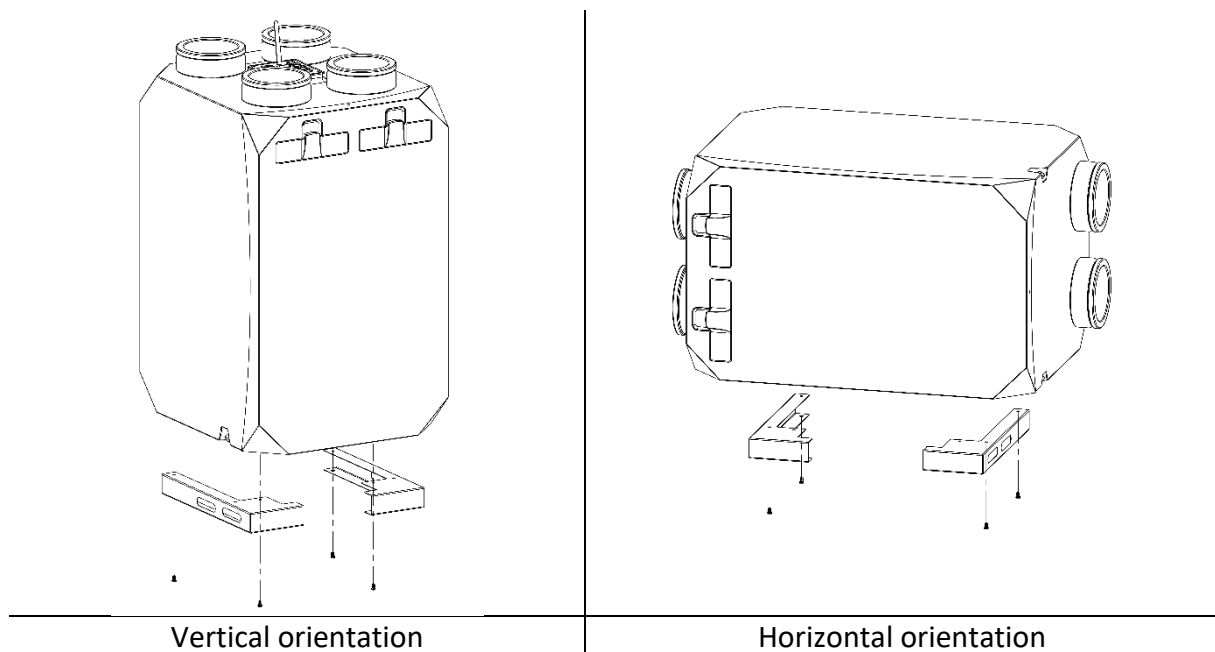

## 17. Wall hanging parts

2 wall hanging parts are used when the device will be installed onto a flat wall.

To install the parts to the device, screw the wall hanging parts to the metal frames on the back side of the device using 8 of the included M5 screws, in the desired orientation of the device.

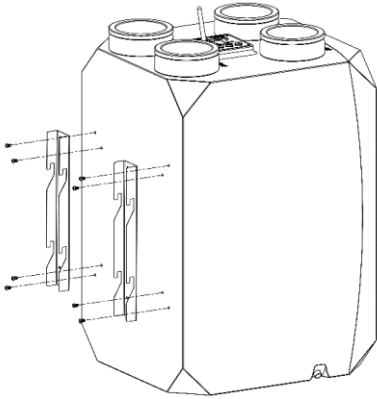

Vertical orientation

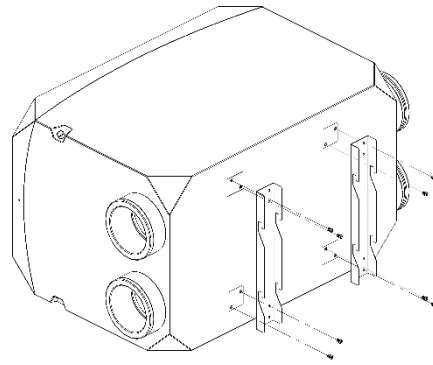

Horizontal orientation

## 18. Wall Fixture part

Wall fixture part is used when the device will be installed onto a flat wall.

1. To prepare the device to be fitted onto the wall, secure the wall fixture part to the wall using appropriate type of dowels for the wall type.

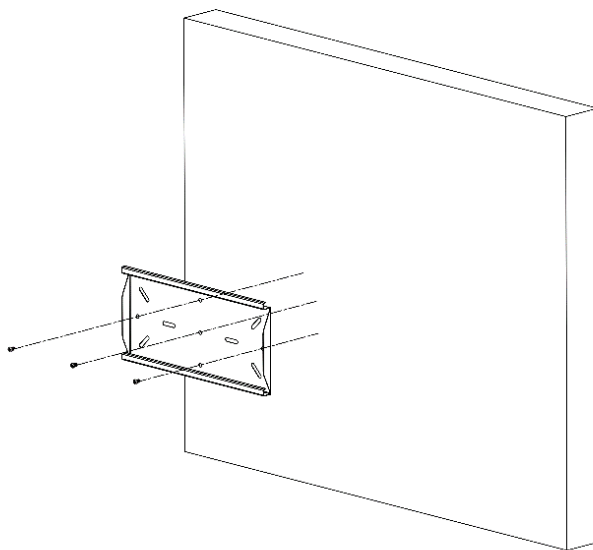

2. Hang the device on to the wall fixture part

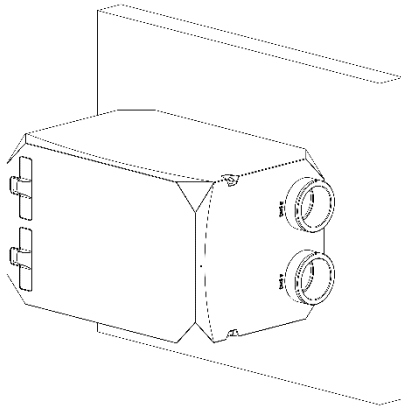
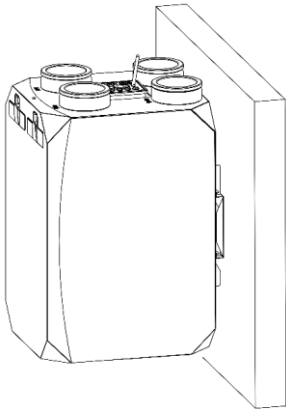
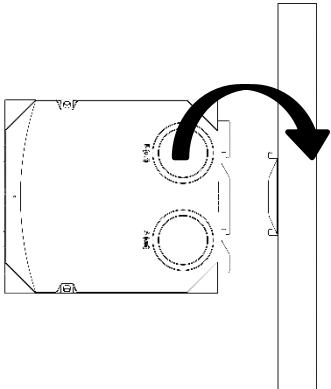
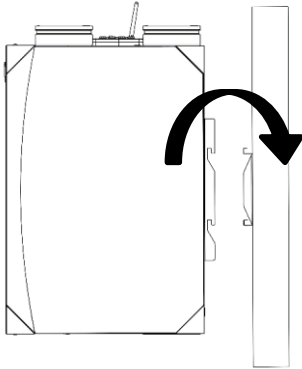

Vertical orientation

Horizontal orientation

# GENERAL WARNINGS

By following these guidelines, you contribute to the safe and efficient operation of the heat recovery device.



## 1. Installation and Commissioning:

Ensure the installation and commissioning of the device are conducted exclusively by qualified personnel to guarantee optimal performance.

## 2. Disassembly and Repair:

The heat recovery device should never be disassembled by users. Only authorized service personnel are permitted to undertake disassembly and repairs to prevent electric shocks or injuries.

## 3. Removal of Protective Materials:

Before powering on the device, remove all protective materials, inside and outside, used during transportation to avoid operational issues.

## 4. Operating Environment:

Do not use the device in heated swimming pools, cold storage rooms, or environments with extreme humidity and heat variations. Avoid exposure to rain to prevent electric shocks and ensure correct device operation.

## 5. Avoid Corrosive and Flammable Environments:

Do not use the device in corrosive environments (acids, oil mist, paint, toxic gases, etc.) or in flammable media containing explosive gases.

## 6. Electrical Specifications:

The device operates at 230V - 50 Hz. Ensure the quality and strength of apparatus (switches, fuses, cables) used with the system.

## **7. Secure Fixing and Handling:**

Securely fix the device, avoiding force on electrical connections and the control box during lifting.

## **8. Drainage and Service Spaces:**

Connect waste water lines to drain pans and maintain a clear service space of at least 50cm in front of the device for filter changes and service door openings.

## **9. Temperature and Humidity Range:**

Operate the device in a temperature range of -10 °C to +40 °C, with a relative humidity below 60%. Consider using an electric pre-heater if temperatures fall below -10 °C consistently.

## **10. Electrical Safety:**

Use apparatus with quality certificates and high strength. Ensure proper power supply with appropriate cables and thermally protected switches.

## **11. Avoid Electrical Contact:**

Ensure the device is not in electrical contact with air ducts and building steel constructions to prevent electrical leaks and fires.

## **12. Circuit Breaker and Electrical Heaters:**

Install a circuit breaker on the mains connection. Electric heaters should be used with the heat recovery device automatic controller, and caution is advised regarding their connections.

## **13. Safety Precautions:**

Switch off electrical connections before any interference with the appliance. Ensure the fan motor is not running before opening service doors.

## **14. Maintenance and Cleaning:**

Regularly clean G4 filters and heat exchangers with compressed air. Avoid cleaning with flammable gases or water. Sharp turns and sudden contractions or expansions in duct systems during installation should be avoided.







**For more information, visit our product website;**

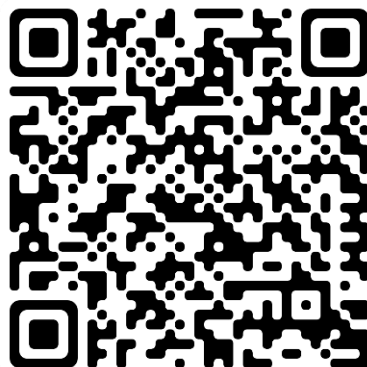

BSK Havalandırma Ekipmanları A.Ş.

Mimar Sinan mah. Basra Cad. No 59/A Sultanbeyli, İstanbul Türkiye

[www.bskhvac.com.tr](http://www.bskhvac.com.tr)